

## RBVR

### Vertical Concealed Floor Mount

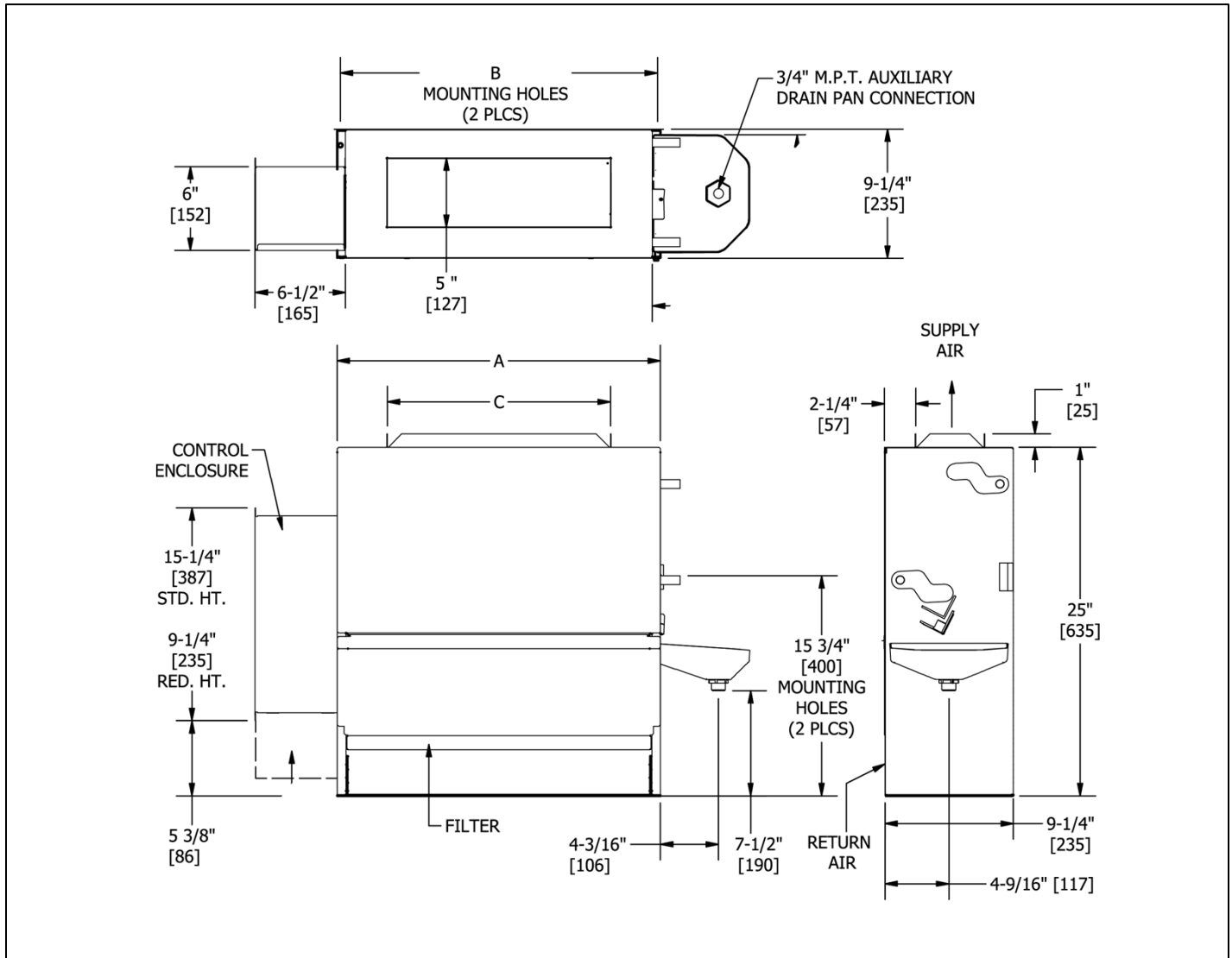

Unit Size	A	B	C
02	23 3/16 [589]	22 3/4 [578]	16 [406]
03	27 3/16 [691]	26 3/4 [679]	20 [508]
04	33 3/16 [843]	32 3/4 [832]	26 [660]
06	43 3/16 [1097]	42 3/4 [1086]	36 [914]
08	45 3/16 [1148]	44 3/4 [1137]	38 [965]
10	59 3/16 [1503]	58 3/4 [1492]	52 [1320]
12	67 3/16 [1707]	66 3/4 [1695]	60 [1524]

**NOTES:**

1. All dimensions are in inches [millimeters]. All dimensions are ± 1/4" [6mm]. Metric values are soft conversion.
2. Junction box size and location varies w/unit features. Control options may be limited. Provide sufficient clearance to access electrical controls and comply w/ applicable codes and ordinances, Reduced height control enclosure is standard with opposite end coils.
3. Right hand coil connection shown. Left hand unit similar but opposite.
4. Some piping package options may require extended drain pans.
5. Size 02 and 03 Models with 208/230vac or 277vac have 3 5/8" [92] extended control enclosure.

**RBVR**

Vertical Concealed Floor Mount, Wall Panel with Front Supply and Return

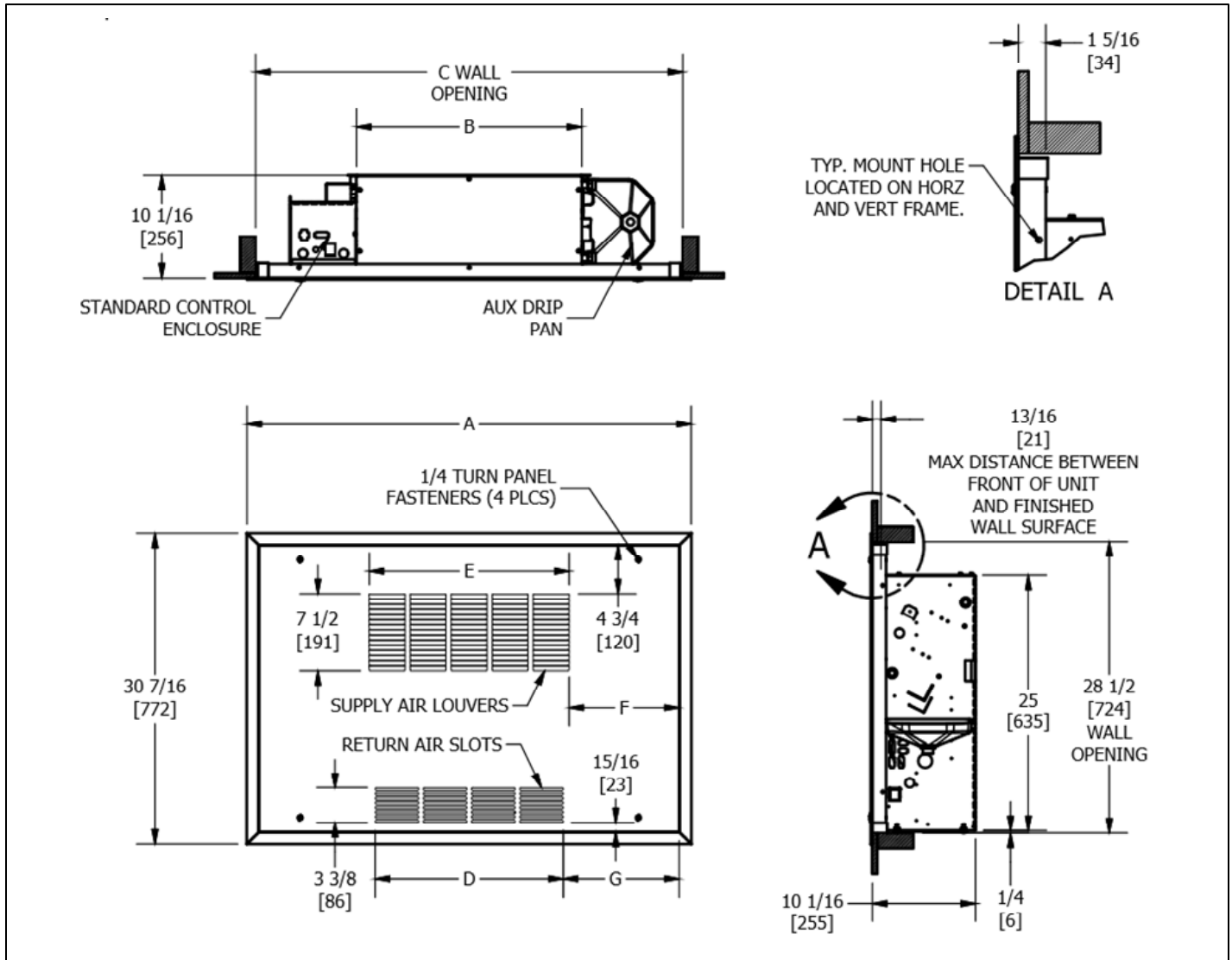

Unit Size	A	B	C	D	E	F	G
02	43 7/16 [1101]	22 [559]	41 11/16 [1059]	18 3/8 [467]	19 1/2 [495]	10 3/4 [273]	11 5/16 [288]
03	47 7/16 [1203]	26 [660]	45 11/16 [1160]	23 1/16 [586]	23 1/2 [597]	10 3/4 [273]	11 [279]
04	53 7/16 [1355]	32 [813]	51 11/16 [1313]	27 3/4 [705]	27 1/2 [699]	11 3/4 [298]	11 5/8 [295]
06	63 7/16 [1609]	42 [1067]	61 11/16 [1567]	37 1/8 [943]	39 1/2 [1003]	10 3/4 [273]	11 15/16 [303]
08	65 7/16 [1660]	44 [1118]	63 11/16 [1618]	41 7/8 [1064]	39 1/2 [1003]	11 3/4 [298]	10 9/16 [269]
10	79 7/16 [2015]	58 [1473]	77 11/16 [1973]	55 15/16 [1421]	55 1/2 [1410]	10 3/4 [273]	10 9/16 [269]
12	87 7/16 [2219]	66 [1676]	85 11/16 [2176]	60 5/8 [1504]	63 1/2 [1613]	10 3/4 [273]	12 3/16 [309]

**NOTES:**

1. All dimensions are in inches [millimeters]. All dimensions are ± 1/4" [6mm]. Metric values are soft conversion.
2. Wall panel provides air seal at front of unit. Installed location is critical to proper unit operation.
3. Install unit centered in wall opening dimensions shown.
4. Unit may require raised support to achieve proper vertical alignment with wall panel.
5. Right hand coil connection shown. Left hand unit similar but opposite.
6. Mounting hardware furnished by others.

**RBVR**

Vertical Concealed Floor Mount, Wall Panel with Top Supply and Front Return

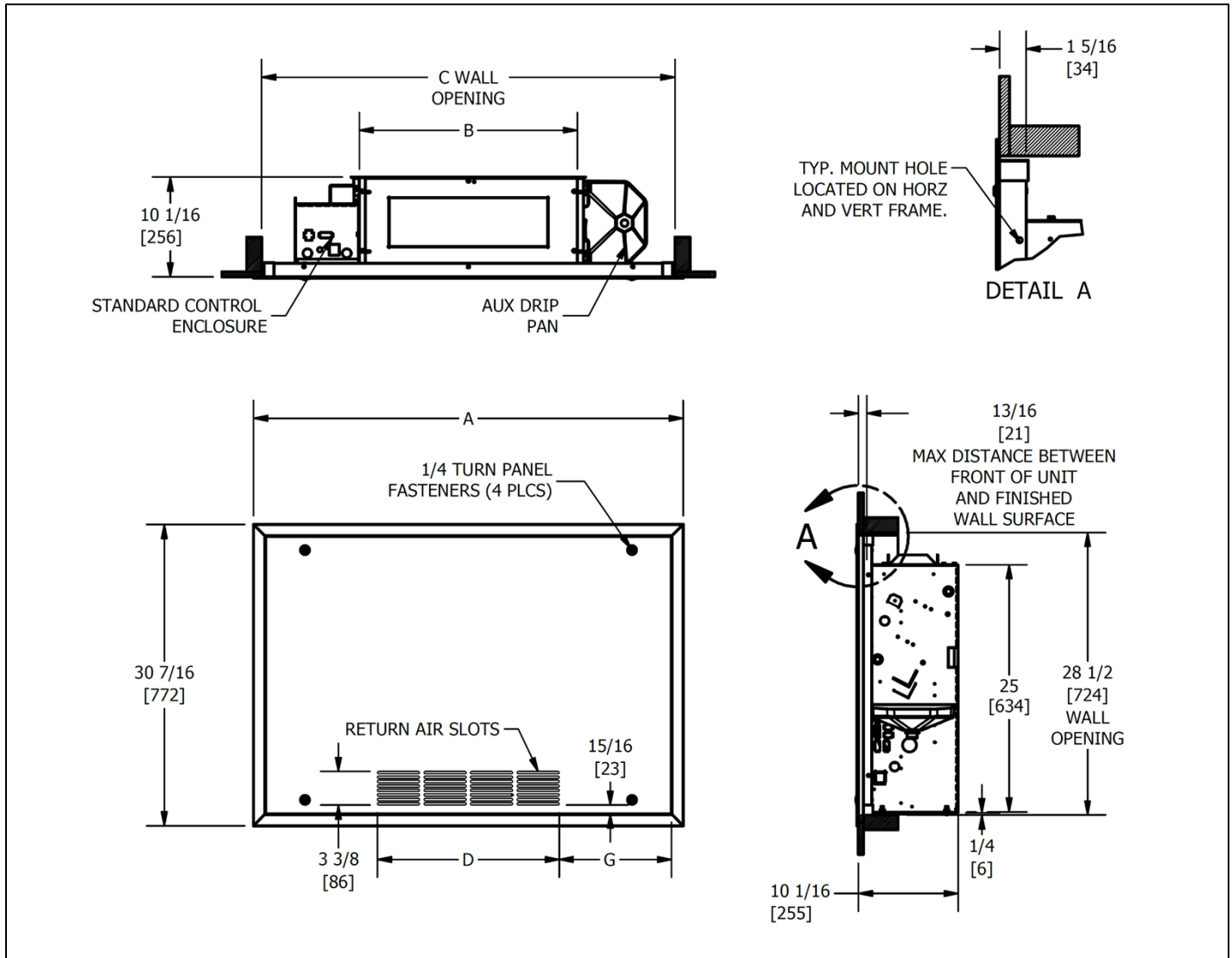

Unit Size	A	B	C	D	G
02	43 7/16 [1101]	22 [559]	41 11/16 [1059]	18 3/8 [467]	11 5/16 [288]
03	47 7/16 [1203]	26 [660]	45 11/16 [1160]	23 1/16 [586]	11 [279]
04	53 7/16 [1355]	32 [813]	51 11/16 [1313]	27 3/4 [705]	11 5/8 [295]
06	63 7/16 [1609]	42 [1067]	61 11/16 [1567]	37 1/8 [943]	11 15/16 [303]
08	65 7/16 [1660]	44 [1118]	63 11/16 [1618]	41 7/8 [1064]	10 9/16 [269]
10	79 7/16 [2015]	58 [1473]	77 11/16 [1973]	55 15/16 [1421]	10 9/16 [269]
12	87 7/16 [2219]	66 [1676]	85 11/16 [2176]	60 5/8 [1504]	12 3/16 [309]

**NOTES:**

1. All dimensions are in inches [millimeters]. All dimensions are ± 1/4 " [6mm]. Metric values are soft conversion.
2. Wall panel provides air seal at front of unit. Installed location is critical to proper unit operation.
3. Install unit centered in wall opening dimensions shown.
4. Unit may require raised support to achieve proper vertical alignment with wall panel.
5. Right hand coil connection shown. Left hand unit similar but opposite.
6. Mounting hardware furnished by others.

**RBVR**

Vertical Concealed Floor Mount, Extended Wall Panel with Front Supply and Return

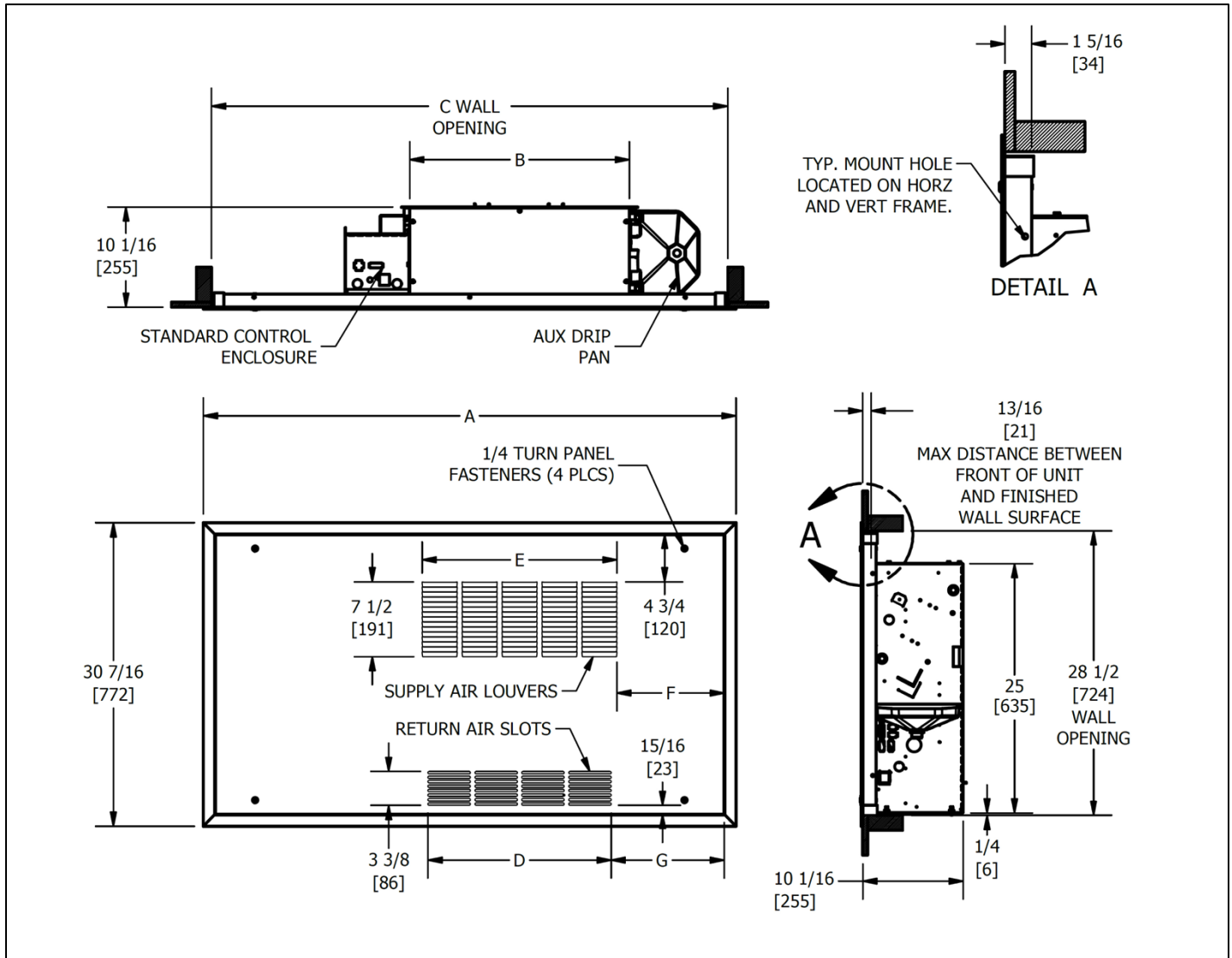

Unit Size	A	B	C	D	E	F	G
02	53 7/16 [1355]	22 [559]	51 11/16 [1313]	18 3/8 [467]	19 1/2 [495]	10 3/4 [273]	11 5/16 [288]
03	57 7/16 [1459]	26 [660]	55 11/16 [1414]	23 1/16 [586]	23 1/2 [597]	10 3/4 [273]	11 [279]
04	63 7/16 [1609]	32 [813]	61 11/16 [1567]	27 3/4 [705]	27 1/2 [699]	11 3/4 [298]	11 5/8 [295]
06	73 7/16 [1865]	42 [1067]	71 11/16 [1821]	37 1/8 [943]	39 1/2 [1003]	10 3/4 [273]	11 15/16 [303]
08	55 7/16 [1916]	44 [1118]	73 11/16 [1872]	41 7/8 [1064]	39 1/2 [1003]	11 3/4 [298]	10 9/16 [269]
10	89 7/16 [2272]	58 [1473]	87 11/16 [2227]	55 15/16 [1421]	55 1/2 [1410]	10 3/4 [273]	10 9/16 [269]
12	97 7/16 [2475]	66 [1676]	95 11/16 [2430]	60 5/8 [1504]	63 1/2 [1613]	10 3/4 [273]	12 3/16 [309]

**NOTES:**

1. All dimensions are in inches [millimeters]. All dimensions are ± 1/4 " [6mm]. Metric values are soft conversion.
2. Wall panel provides air seal at front of unit. Installed location is critical to proper unit operation.
3. Install unit centered in wall opening dimensions shown.
4. Unit may require raised support to achieve proper vertical alignment with wall panel.
5. Right hand coil connection shown. Left hand unit similar but opposite.
6. Mounting hardware furnished by others.

**RBVR**

Vertical Concealed Floor Mount, Extended Wall Panel with Top Supply and Front Return

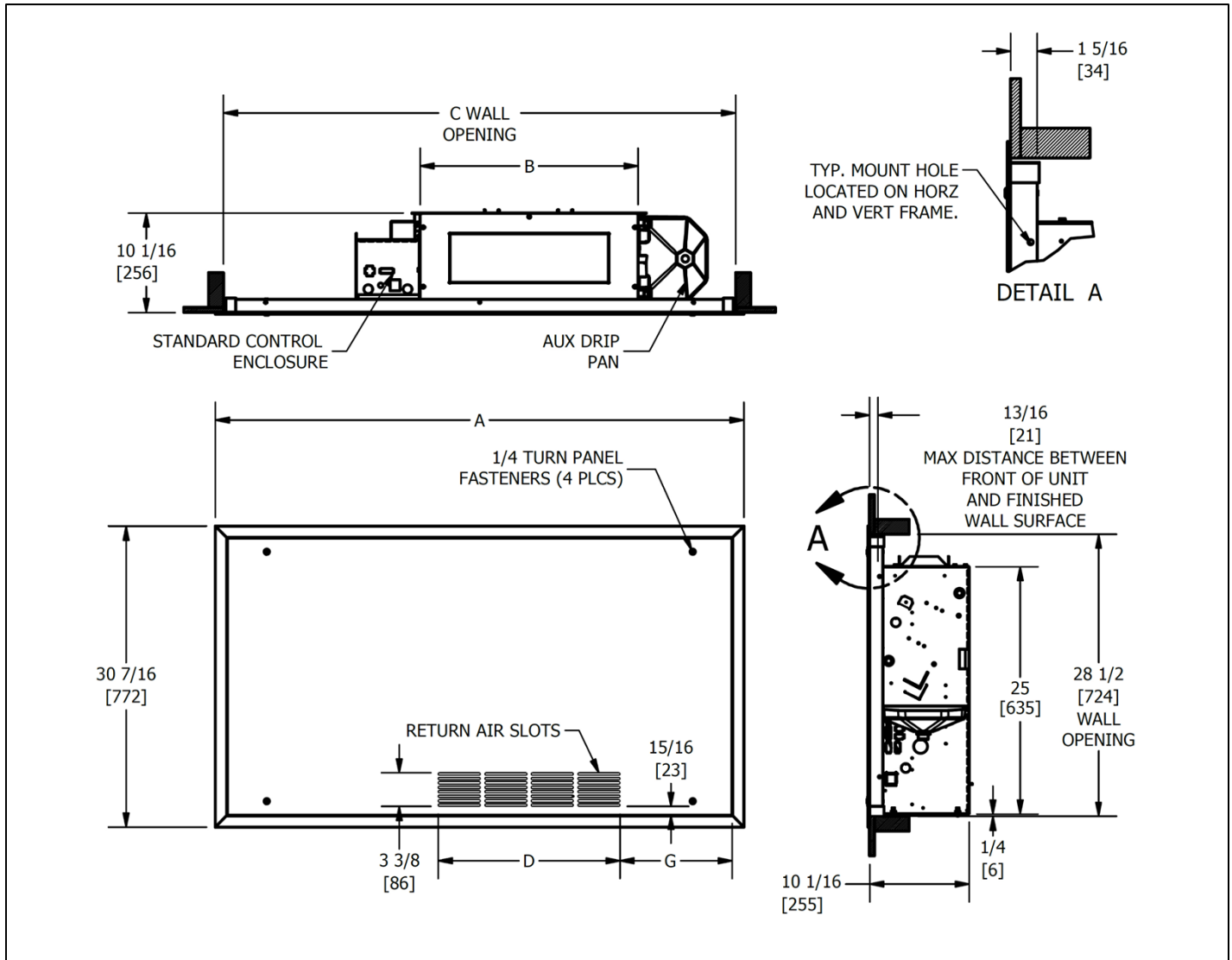

Unit Size	A	B	C	D	G
02	53 7/16 [1355]	22 [559]	51 11/16 [1313]	18 3/8 [467]	11 5/16 [288]
03	57 7/16 [1459]	26 [660]	55 11/16 [1414]	23 1/16 [586]	11 [279]
04	63 7/16 [1609]	32 [813]	61 11/16 [1567]	27 3/4 [705]	11 5/8 [295]
06	73 7/16 [1865]	42 [1067]	71 11/16 [1821]	37 1/8 [943]	11 15/16 [303]
08	55 7/16 [1916]	44 [1118]	73 11/16 [1872]	41 7/8 [1064]	10 9/16 [269]
10	89 7/16 [2272]	58 [1473]	87 11/16 [2227]	55 15/16 [1421]	10 9/16 [269]
12	97 7/16 [2475]	66 [1676]	95 11/16 [2430]	60 5/8 [1504]	12 3/16 [309]

**NOTES:**

1. All dimensions are in inches [millimeters]. All dimensions are  $\pm 1/4$  " [6mm]. Metric values are soft conversion.
2. Wall panel provides air seal at front of unit. Installed location is critical to proper unit operation.
3. Install unit centered in wall opening dimensions shown.
4. Unit may require raised support to achieve proper vertical alignment with wall panel.
5. Right hand coil connection shown. Left hand unit similar but opposite.
6. Mounting hardware furnished by others.

RBVR, Outside Air Damper

**OUTSIDE AIR DAMPER**

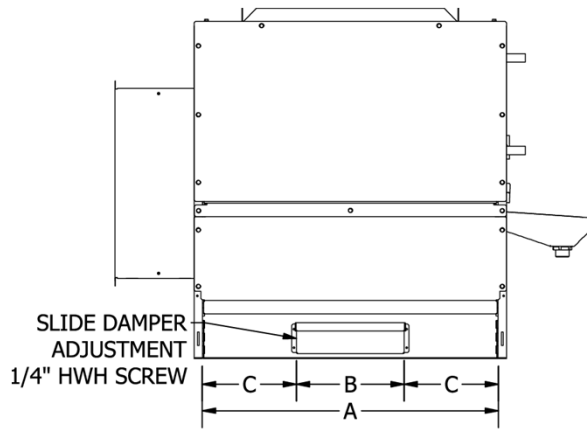

**MANUAL DAMPER OPTION**

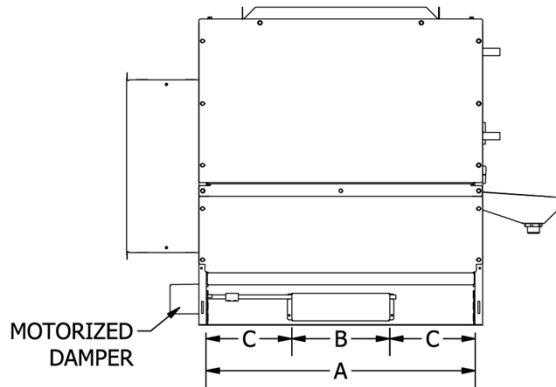
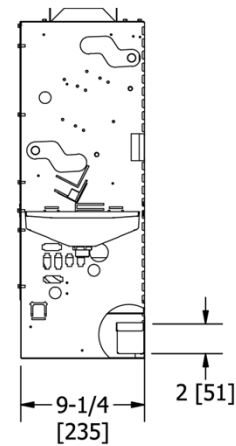

**MOTORIZED DAMPER OPTION**

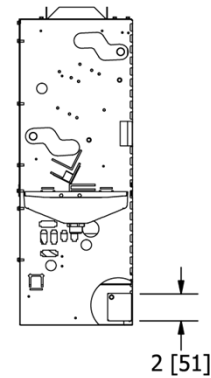

Unit Size	A	B	C
02	22 [559]	8 [203]	7 [178]
03	26 [660]	10 [254]	8 [203]
04	32 [813]	12 [305]	10 [254]
06	42 [1067]	14 [356]	14 [356]
08	44 [1118]	18 [457]	13 [330]
10	58 [1473]	27 [686]	15 ½ [394]
12	66 [1676]	27 [686]	19 ½ [495]

**NOTES:**

1. All dimensions are inches [millimeters]. All dimensions are ± 1/4" [6mm]. Metric values are soft conversion.
2. Model RBVR shown; typical for Models RBVS and RBVC.
3. The standard damper options may not provide freeze protection under all conditions and applications. Other forms of freeze protection may be required.
4. Right hand unit shown; left hand unit is similar but opposite.

**RBVR, Outside Air Wall Box**

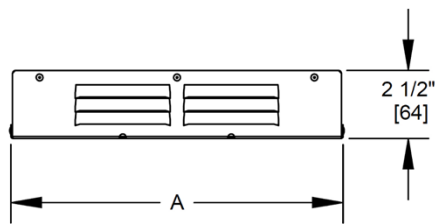
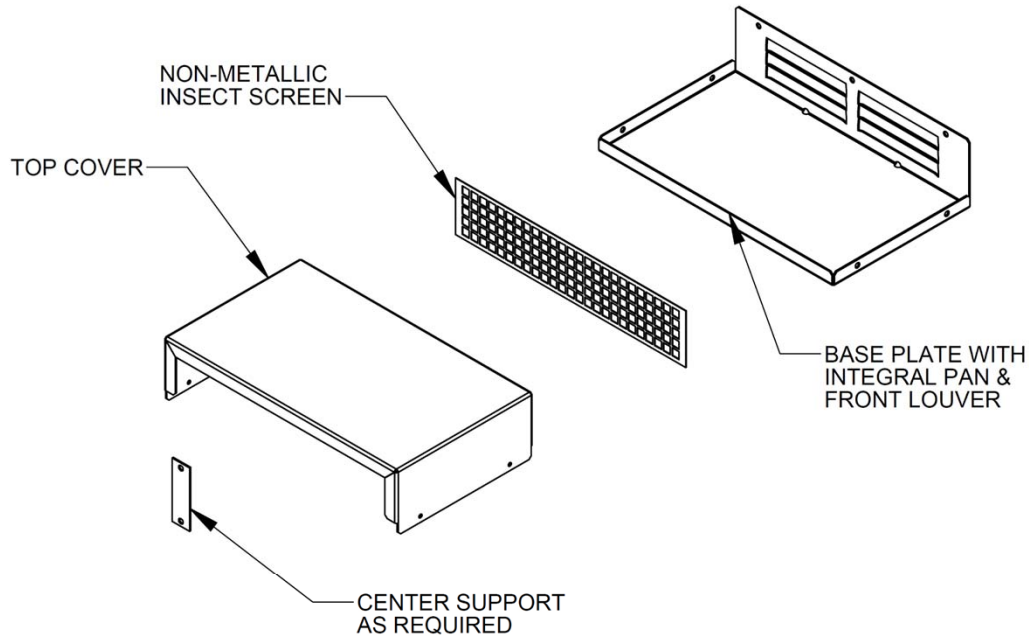

SLOPE  
SEE NOTE 2

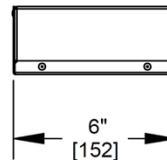

Unit Size	A
02	8 1/4 [203]
03	10 1/4 [260]
04	12 1/4 [311]
06	14 1/4 [362]
08	18 1/4 [464]
10	27 1/4 [692]
12	27 1/4 [692]

**NOTES:**

1. All dimensions are inches [millimeters]. All dimensions are  $\pm 1/4$ " [6mm]. Metric values are soft conversion.
2. Material is 0.05" thick aluminum.
3. Wall box should be installed pitched slightly toward exterior surface of wall.
4. "Weep" holes should not be obstructed when sealing box to the wall.

## General Notes - Piping Packages

- All the packages and components described in this brochure are optional, extra cost features. Consult your Superior Rex sales representative for details. Not all components are available on all unit models. See valve package code charts.
- All standard valve packages and piping components described in this catalog are for chilled and hot water applications. They may also be used with ethylene and propylene glycol solutions up to 50% concentration.
- RBH, RAH, and RBV fan coil unit packages – are factory assembled and shipped loose for field installation and wiring. All RAV fan coil unit packages are factory assembled, installed, and wired.
- RBH, RAH and RBV unit valve packages are designed to mount directly onto the coil connections.
- Control valve actuators are removable, and may be serviced or replaced without removal of the valve body.
- Control valves are piped normally closed to the coil. For hot water coils, control valves are available normally open.
- 3-Way control valves are piped as mixing valves.
- All ball isolation valves are furnished with an adjustable memory stop feature and may be used as a balancing valve.
- When ordered, unions are installed at the water coil, and are available on all fan coil units except RAV.  
Unions must be ordered on both coils of 4-pipe units. Unions are not available separately.
- All RAV units include two flexible stainless steel braided hoses and ball isolation valves per coil. This hose/valve combination provides a "union" type connection to allow coil removal.
- Pressure/temperature (P/T) ports are located to monitor the pressure and temperature across the coil.
- Automatic fixed flow controls (FC, FCN, FCS) are available in flow (GPM) ratings as follows:
  - 1/2" = 0.5 to 4.0 GPM in 0.5 GPM increments
  - >4.0 to 9.0 GPM in 1.0 GPM increments
  - 3/4" = 3.0 to 4.0 GPM in 0.5 GPM increments
  - >4.0 to 12.0 GPM in 1.0 GPM increments
  - 1" = 5.0 to 10.0 GPM in 1.0 GPM increments
  - >10.0 to 20.0 GPM in 2.0 GPM increments
 Individual coil GPM requirements must be specified at time of order.
- Component performance ratings such as Cv, maximum close-off pressure, operating temperature and pressure, are shown in Component Specifications.
- Valve and component performance ratings shown are maximum values. Appearance and actual ratings may vary with individual vendor and component size.
- Adjustable flow setter (AFS) is rated for full shut-off and replaces the return line ball isolation valve on all products except the RAV fan coil unit.
- 2-Pipe "change-over" units using a 2-way control valve and factory thermostat must be ordered with a "E" "bleed" line to assure proper changeover thermostat (aquastat) operation. The "E" "bleed" line is optional on 2-pipe "changeover" units with field provided thermostats.
- Some piping packages may extend beyond the unit drain pan and/or factory auxiliary drip pan. Requirements for field furnished and installed valve package and piping insulation must be determined by others on an individual application basis.  
**The valve package piping and component details shown in this catalog are for standard valves and components. The suitability of all valve packages and components must be determined by others based on individual application requirements. Superior Rex assumes no responsibility for selection and/or application of valve packages and components. Modulating cooling valve control can increase part load space relative humidity. Superior Rex does not encourage or endorse modulating valve control for fan coil cooling systems, and is not liable for high humidity problems that may result. Modulating heating valve control may result in low leaving air temperatures while the valve reduces flow and as setpoint is approached.**  
Contact Superior Rex for any requirements not shown in this catalog.

## CONTROL DEVICE LEGEND

MANUAL BALL VALVE WITH MEMORY STOP (BVMS)		2-WAY CONTROL VALVE		3-WAY CONTROL VALVE	
FIXED FLOW CONTROL VALVE (FC)		AUTOMATIC CARTRIDGE FLOW CONTROL WITHOUT SCREEN		AUTOMATIC CARTRIDGE FLOW CONTROL WITH SCREEN	
ADJUSTABLE FLOW CIRCUIT SETTER (AFS)		BYPASS BALANCE VALVE (BPV)		PRESSURE-TEMPERATURE TEST PORT (PT)	
Y-STRAINER (Y-STR)		Y-STRAINER W/CLEANOUT VALVE (YCO)		UNION	
FLEXIBLE HOSE (FH)		AQUA-THERMOSTAT		SCHRADER FITTING	

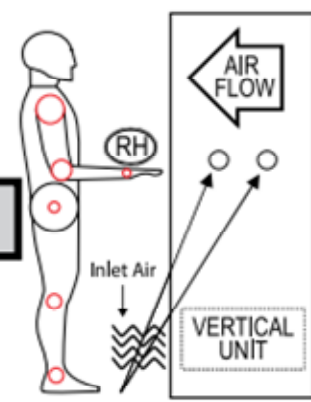
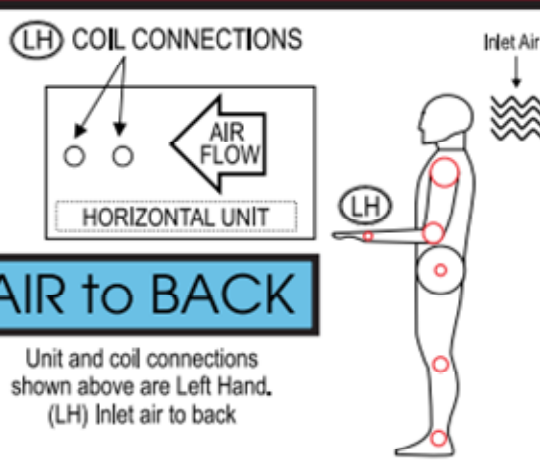

**Coil Handing**

<b>COIL/UNIT HANDING GUIDE</b>	
<div style="border: 1px solid black; padding: 5px; margin-bottom: 10px; background-color: #f0f0f0;"><b>AIR to BACK</b></div>  <p>Unit and coil connections shown above are Right Hand. (RH) Inlet air to back</p> <p style="text-align: center;">(RH) COIL CONNECTIONS</p>	<div style="border: 1px solid black; padding: 5px; margin-bottom: 10px; background-color: #e0f0ff;"><b>AIR to BACK</b></div>  <p>Unit and coil connections shown above are Left Hand. (LH) Inlet air to back</p>
<b>Vertical Largo Units are handed as "Inlet Air to Back"</b>	<b>Horizontal Largo Units are handed as "Inlet Air to Back"</b>
RBV	RAH
RAV	RBH
SSL/SBS	SBH/SBV
	SBM

## RBVR, Piping Packages

2-WAY PIPING PACKAGE												
Package Code	Components			Valve Size			Unions			P/T Ports	1/4" Bleed Line	Y-STR w/ BDV
	BVMS	FC	AFS	1/2"	3/4"	1"	1/2"	3/4"	1"			
24	X									X	X	X
25	X	X		X	X	X	X	X	X	X	X	X
29	X		X							X	X	X

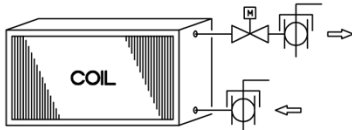

Code 24

2-Way Control Valve and Ball Valves With Memory Stop

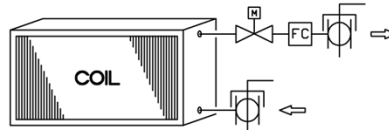

Code 25

2-Way Control Valve, Ball Valves with Memory Stop, and Fixed Flow Control

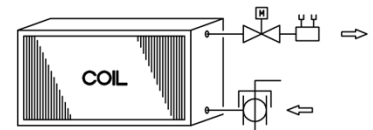

Code 29

2-Way Control Valve, Ball Valve with Memory Stop, and Adjustable Flow Setter

3-WAY PIPING PACKAGE												
Package Code	Components			Valve Size			Unions			P/T Ports	Y-STR w/ BDV	
	BVMS	FC	AFS	1/2"	3/4"	1"	1/2"	3/4"	1"			
36	X									X	X	
37	X	X		X	X	X	X	X	X	X	X	
41	X		X							X	X	

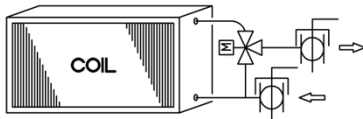

Code 36

3-Way Control Valve and Ball Valves With Memory Stop

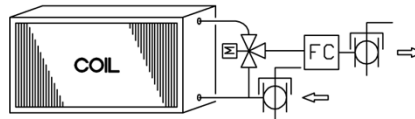

Code 37

3-Way Control Valve, Ball Valves with Memory Stop, and Fixed Flow Control

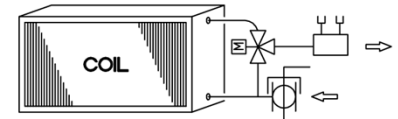

Code 41

3-Way Control Valve, Ball Valve With Memory Stop, and Adjustable Flow Setter

3-WAY PACKAGE WITH BALANCE BYPASS VALVE												
Package Code	Components			Valve Size			Unions			P/T Ports		
	BVMS	FC	AFS	1/2"	3/4"	1"	1/2"	3/4"	1"			
50	X			X	X	X	X	X	X	X		
53	X		X							X		

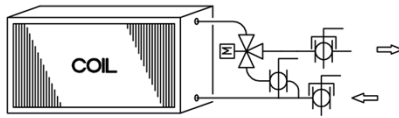

Code 50

3-Way Control Valve, Ball Valve in Bypass, and Ball Valves With Memory Stop

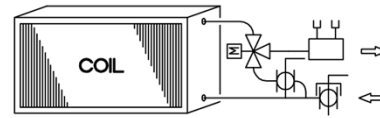

Code 53

3-Way Control Valve, Ball Valve in Bypass, Ball Valve With Memory Stop, and Adjustable Flow Setter

### LEGEND, COMPONENT PRESSURE RATINGS

BVMS:	Manual Ball Valves w/Memory Stop, 600 PSIG
FC:	Fixed Flow Control, Device A = 600 PSIG; Device B = 500 PSIG
AFS:	Adjustable Flow Circuit Setter, 300 PSIG
P/T Port:	Pressure/Temperature Test Port, 400 PSIG
Union:	125 PSIG (contact factory for 600 PSIG)
Control Valve:	300 PSIG
BPV:	Balance Bypass Valve, 400 PSIG
Y-STR W/ BDV:	Y-Strainer

### NOTES:

- All drawings subject to change without prior notice.
- Diagrams show component position in relation to fluid flow. Actual valve package configuration varies with unit type, hand connection, pipe size and options.
- 1/4" bleed line is required on 2-pipe cool and heat auto changeover systems with factory provided thermostats; optional for thermostats by others.
- Unions provided as standard on all RBV piping packages.

**RBVR, Hydronic Coil Connection**

Hydronic Coil Connections (Coil 1 Only)

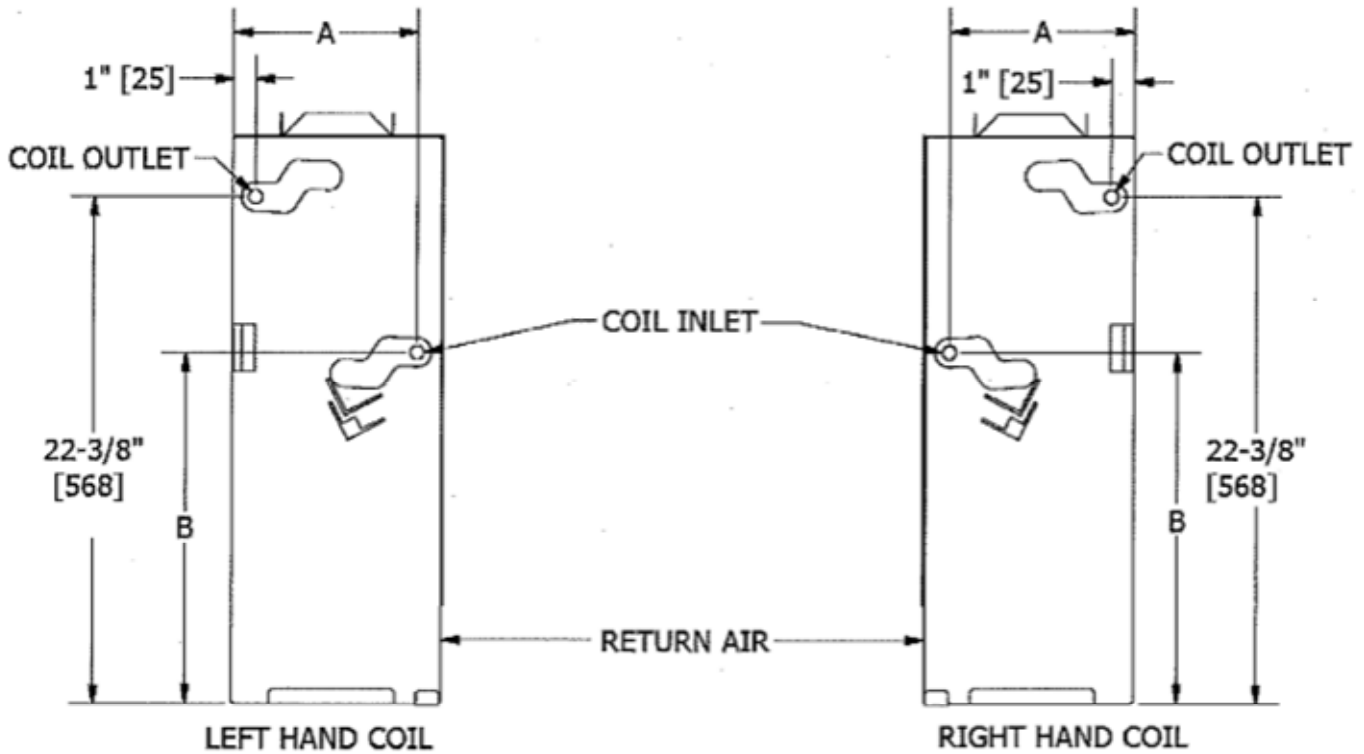

2- Pipe Hydronic Coil									
Coil #1	Dimension	1-Row HW		2-Row CW or HW		3-Row CW		4-Row CW (See Note #2)	
		inches	mm	inches	mm	inches	mm	inches	mm
	A	6.00	152	7.25	184	7.87	200	8.12	206
B	14.57	370	14.64	372	15.68	398	15.50	394	

Coil Connection Types														
Unit Size	Chilled Water (CW)						Hot Water (HW)				Steam			
	2-Row		3-Row		4-Row		1-Row		2-Row		1-Row		2-Row	
	Inches	mm	Inches	mm	Inches	mm	Inches	mm	Inches	mm	Inches	mm	Inches	mm
	5/8	16	5/8	16	5/8	16	5/8	16	5/8	16	5/8	16	5/8	16
02 Thru 12	DX													
	2-Row				3-Row				4-Row					
	Liquid		Suction		Liquid		Suction		Liquid		Suction			
	Inches	mm	Inches	mm	Inches	mm	Inches	mm	Inches	mm	Inches	mm		
	3/8	10	5/8	16	3/8	10	5/8	16	3/8	10	5/8	16		

NOTES:

1. See Coil Connection Table located on Page 11.
2. 4-Row coil not available with electric heat.

**RBVR, Hydronic Coil Connections (2 Coil Configuration)**

Hydronic Coil Connections (Coil 1 & Coil 2)

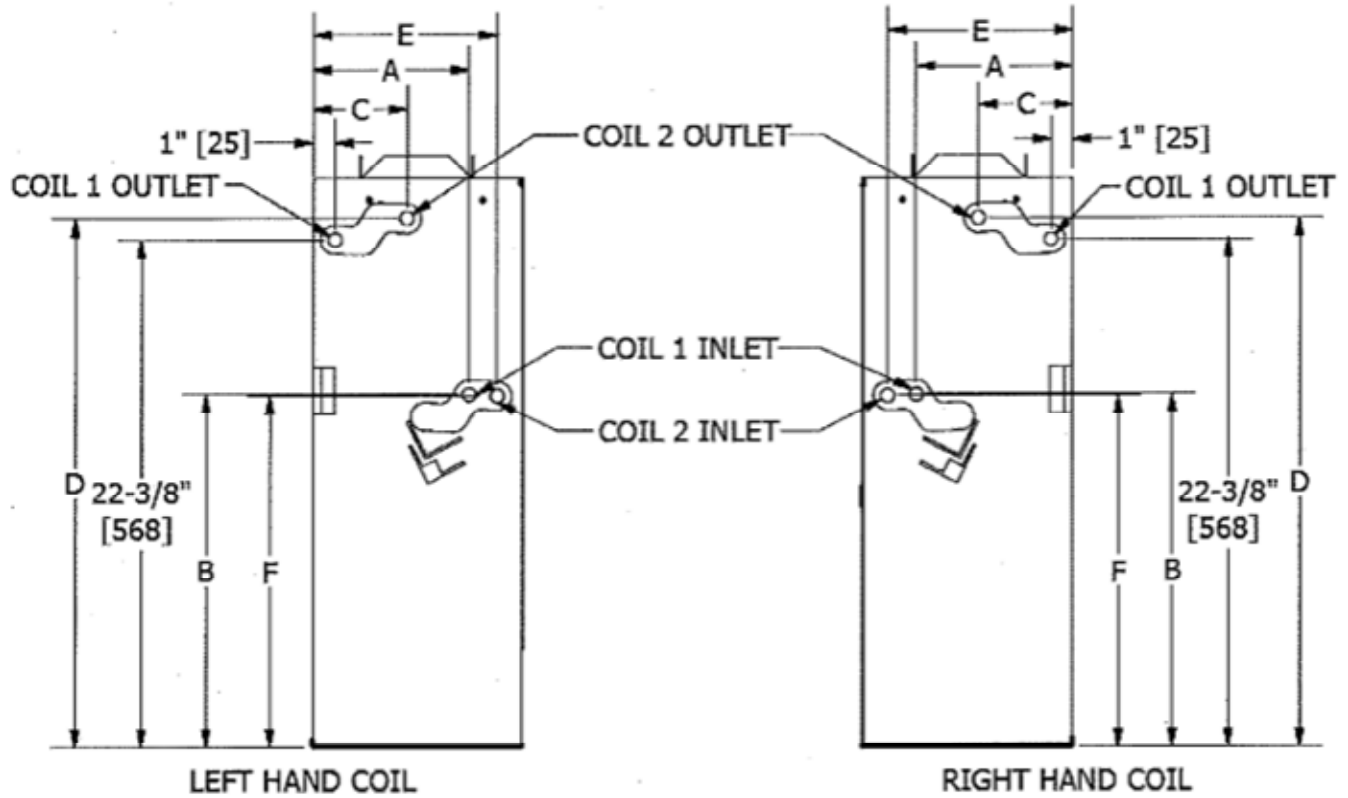

4-Pipe Hydronic Coils											
Coil #1	Dimension	1-Row HW only		2-Row CW or HW				3-Row CW or HW			
		inches	mm	inches		mm		inches	mm		
		A	6.00	152	7.25	184	7.87	200			
B	14.57	370	14.64	372	15.68	398					
Coil #2	Dimension	2-Row CW		3-Row CW		1-Row CW or HW		2-Row CW or HW		1-Row CW or HW	
		inches	mm	inches	mm	inches	mm	inches	mm	inches	mm
	C	2.22	56	2.22	56	2.90	74	2.90	74	4.15	105
	D	22.30	566	22.30	566	23.35	593	23.35	593	23.28	591
	E	6.88	175	8.13	207	6.88	175	8.13	207	8.13	207
F	15.55	395	15.45	391	15.55	395	15.45	391	15.45	391	

NOTES:

1. See Coil Connection Table located on Page 11.

**RBVR, Steam Coil Connection**

Steam Coil Connections (Coil 1 Only)

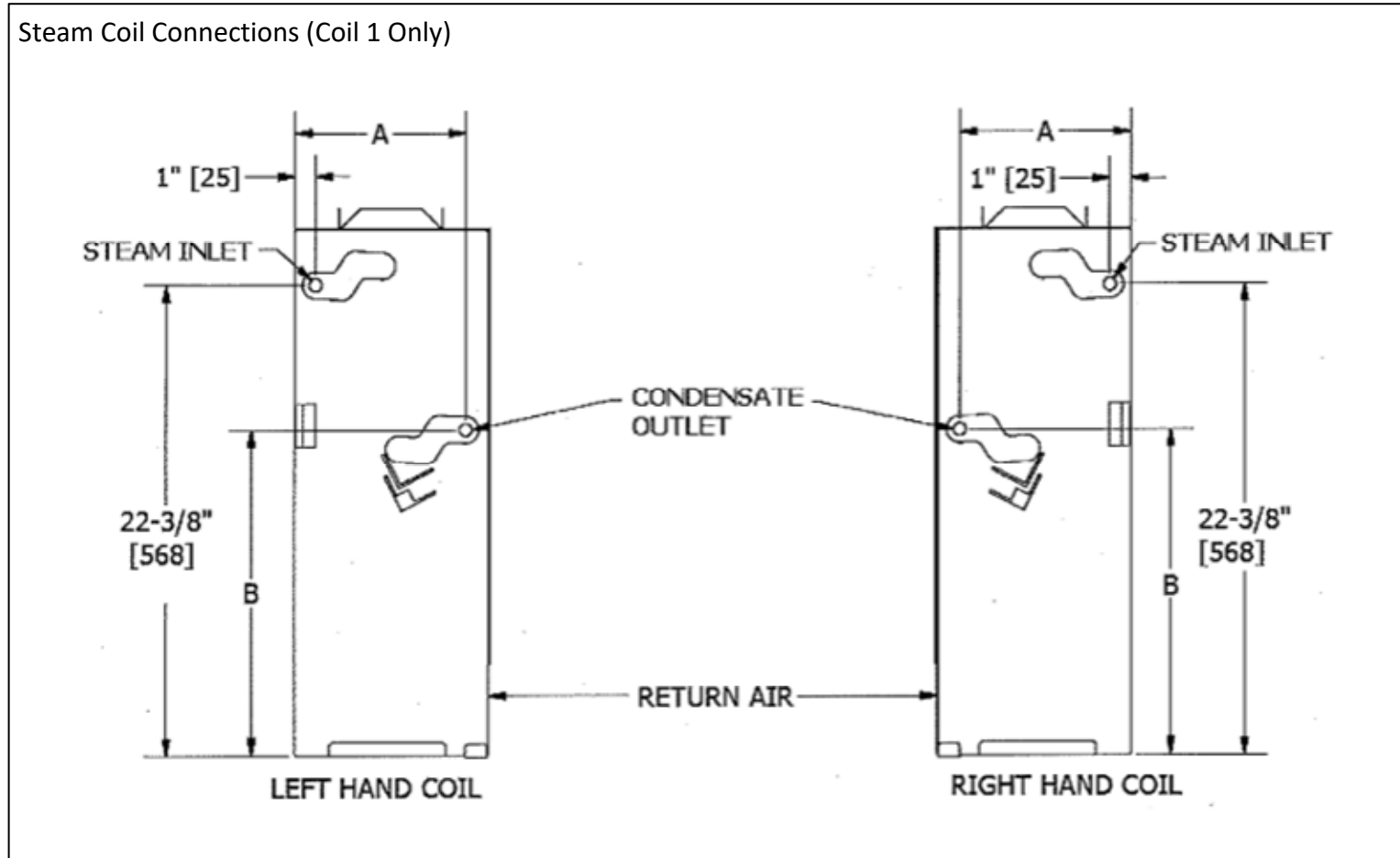

2- Pipe Steam Coil					
Coil #1	Dimension	1-Row Steam		2-Row Steam	
		inches	mm	inches	mm
	A	6.00	152	7.25	184
B	14.57	370	14.64	372	

NOTES:

1. See Coil Connection Table located on Page 11.

**RBVR, DX Coil Connection**

DX Coil Connections (Coil 1 Only)

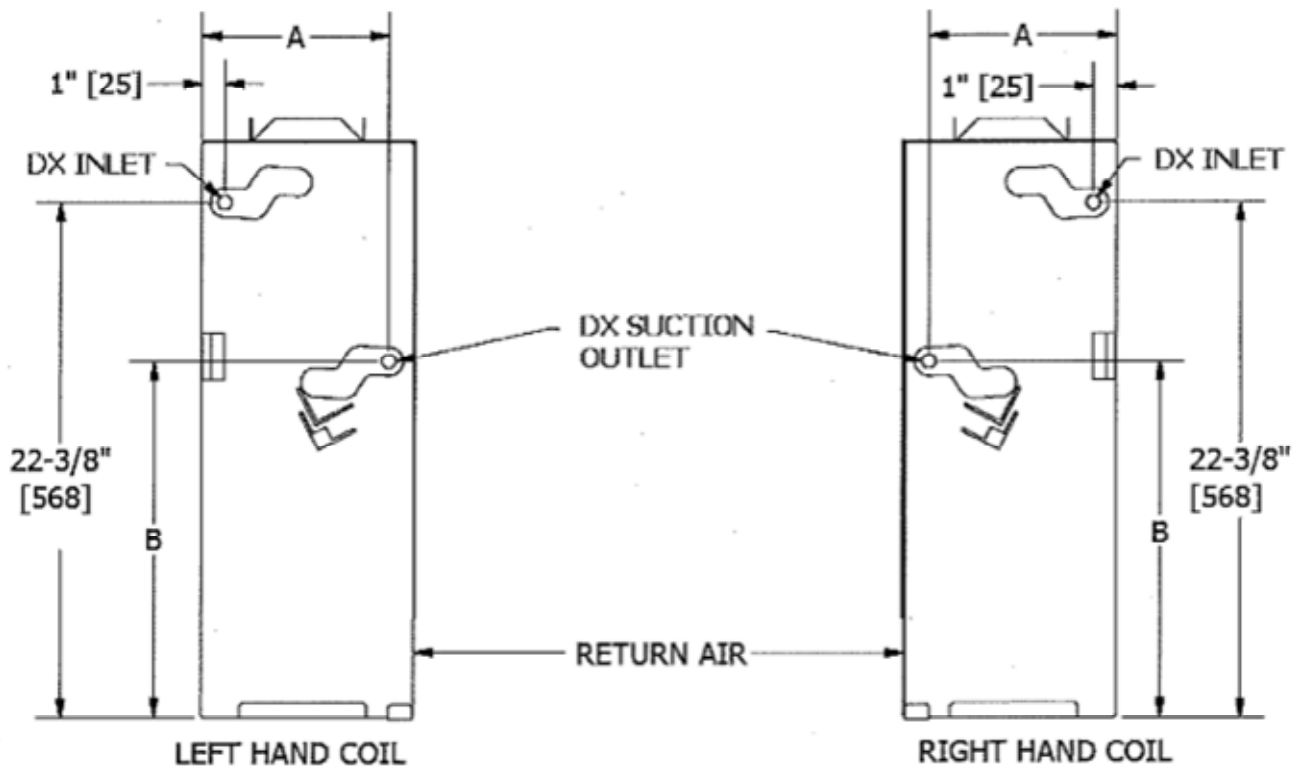

2- Pipe DX Coil							
Coil #1	Dimension	2-Row DX		3-Row DX		4-Row DX (See note #2)	
		inches	mm	inches	mm	inches	mm
	A	7.25	184	7.87	200	8.12	206
B	14.64	372	15.68	398	15.50	394	

NOTES:

1. See Coil Connection Table located on Page 11.
2. 4-Row coil not available with electric heat.

**RBVR, Hydronic/ DX/ Steam Coil Connections (2 Coil Configuration)**

Hydronic/ DX/ Steam Coil Connections (Coil 1 & Coil 2)

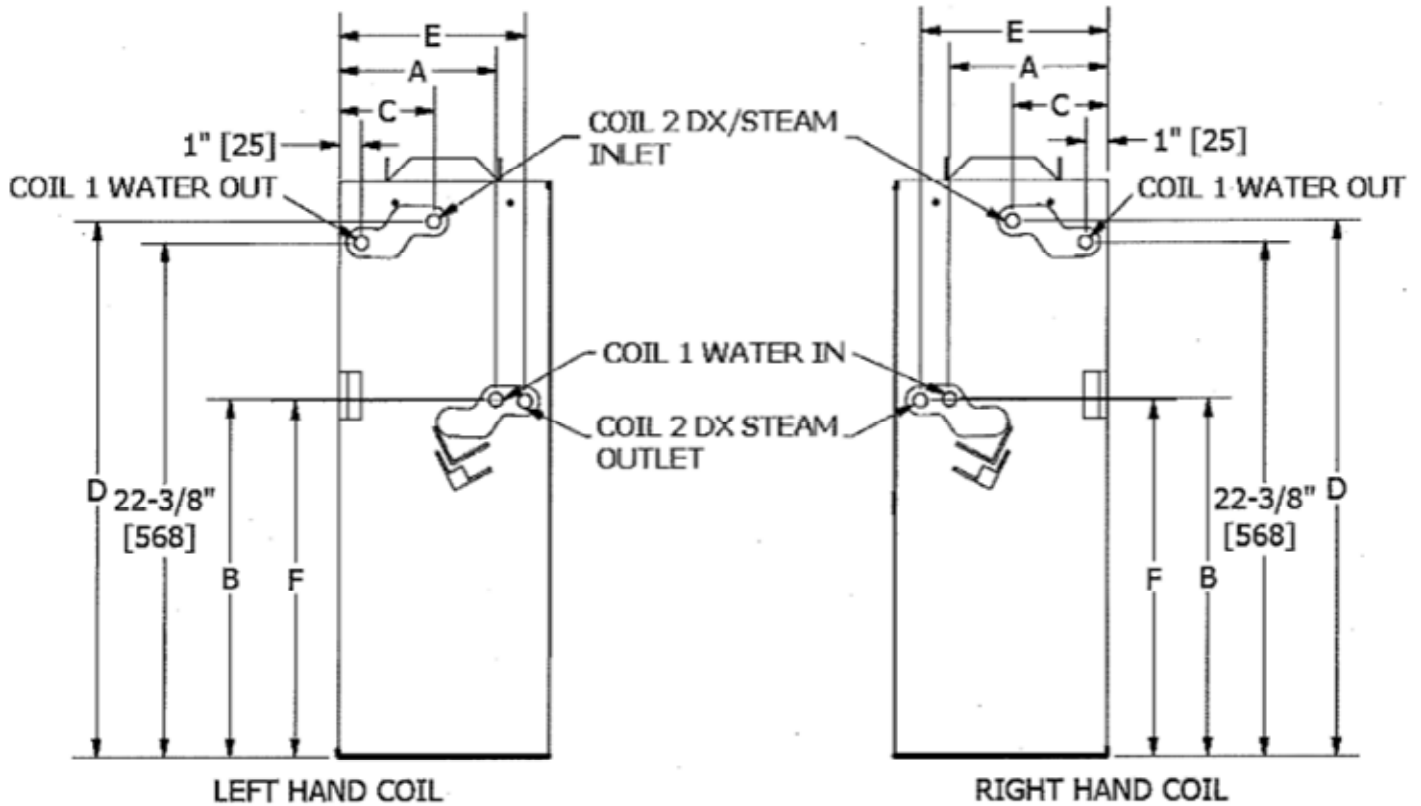

4-Pipe Hydronic/ DX/ Steam Coils												
Coil #1	Dimension	1-Row HW only		2-Row CW or HW		3-Row CW or HW						
		inches	mm	inches	mm	inches	mm					
	A	6.00	152	7.25	184	8.12	206					
	B	14.57	370	14.64	372	15.50	394					
Coil #2	Dimension	2-Row DX or Steam		3-Row DX		1-Row Steam		2-Row DX or Steam		1-Row Steam		
		inches	mm	inches	mm	inches	mm	inches	mm	inches	mm	
		C	2.22	56	2.22	56	2.90	74	2.90	74	4.15	105
		D	22.30	566	22.30	566	23.35	593	23.35	593	23.28	591
		E	6.88	175	8.13	207	6.88	175	8.13	207	8.13	207
	F	15.55	395	15.45	391	15.55	395	15.45	391	15.45	391	

NOTES:

1. See Coil Connection Table located on Page 11.

**RBVR, Hydronic/ DX/ Steam Coil Connections (2 Coil Configuration)**

Hydronic/ DX/ Steam Coil Connections (Coil 1 & Coil 2)

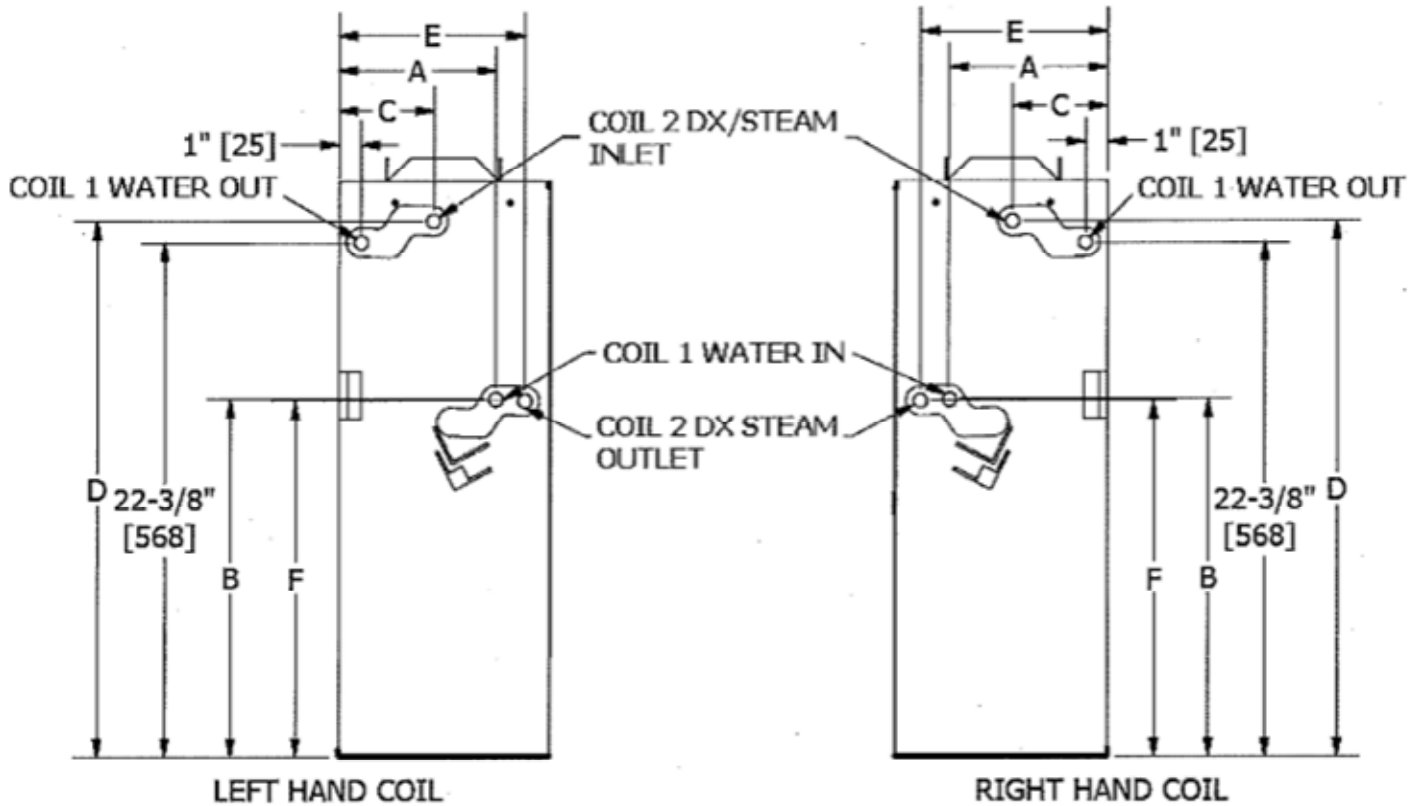

4-Pipe Hydronic/ DX/ Steam Coils												
Coil #1	Dimension	1-Row HW only		2-Row CW or HW		3-Row CW or HW						
		inches	mm	inches	mm	inches	mm					
	A	6.00	152	7.25	184	8.12	206					
	B	14.57	370	14.64	372	15.50	394					
Coil #2	Dimension	2-Row DX or Steam		3-Row DX		1-Row Steam		2-Row DX or Steam		1-Row Steam		
		inches	mm	inches	mm	inches	mm	inches	mm	inches	mm	
		C	2.22	56	2.22	56	2.90	74	2.90	74	4.15	105
		D	22.30	566	22.30	566	23.35	593	23.35	593	23.28	591
		E	6.88	175	8.13	207	6.88	175	8.13	207	8.13	207
	F	15.55	395	15.45	391	15.55	395	15.45	391	15.45	391	

NOTES:

1. See Coil Connection Table located on Page 11.



**RBVR, DX/ Steam Coil Connections (2 Coil Configuration)**

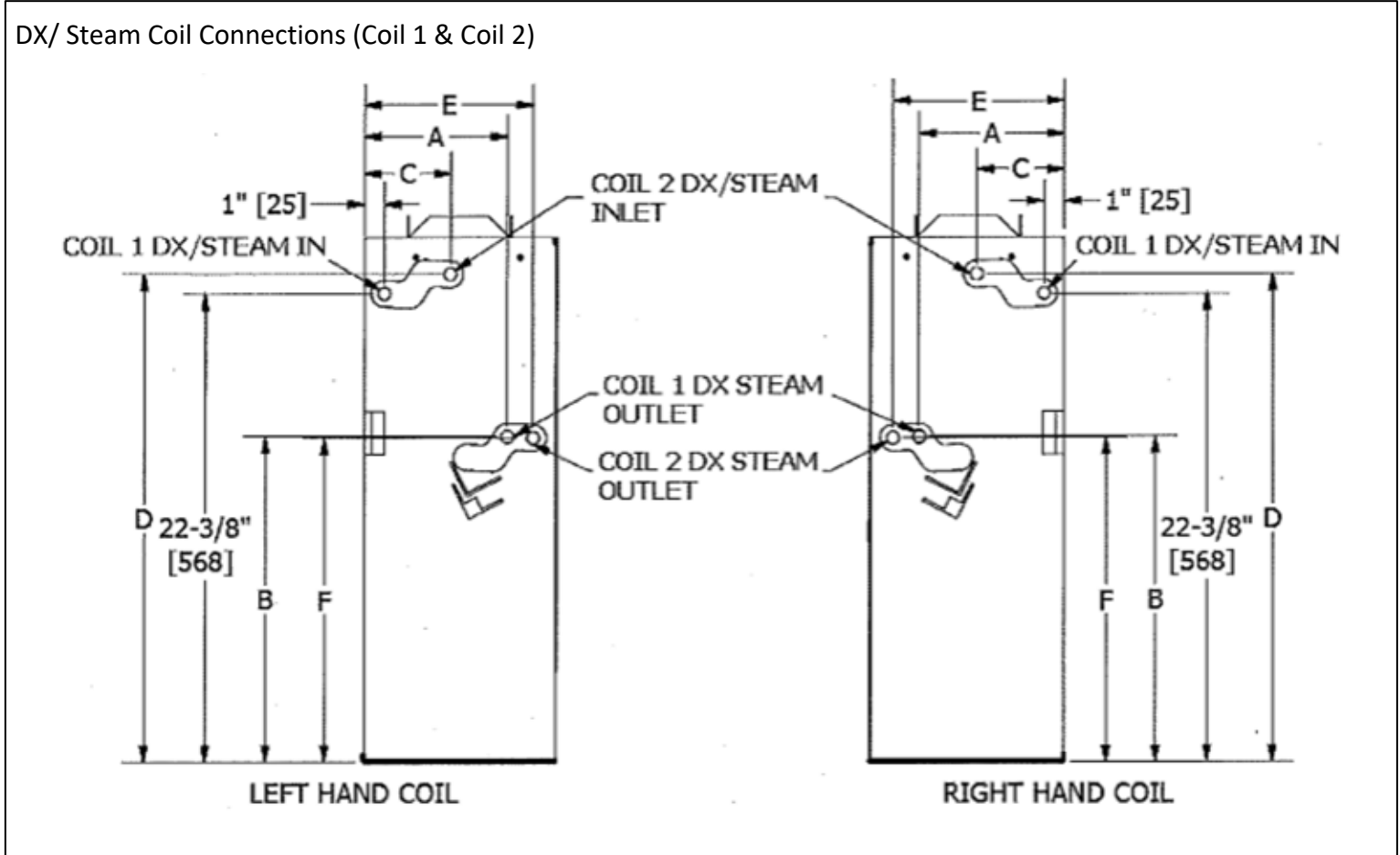

4-Pipe DX/ Steam Coils												
Coil #1	Dimension	1-Row Steam		2-Row DX or Steam		3-Row DX						
		inches	mm	inches	mm	inches	mm					
	A	6.00	152	7.25	184	7.87	200					
	B	14.57	370	14.64	372	15.68	398					
Coil #2	Dimension	2-Row DX or Steam		3-Row DX		1-Row Steam		2-Row DX or Steam		1-Row Steam		
		inches	mm	inches	mm	inches	mm	inches	mm	inches	mm	
		C	2.22	56	2.22	56	2.90	74	2.90	74	4.15	105
		D	22.30	566	22.30	566	23.35	593	23.35	593	23.28	591
		E	6.88	175	8.13	207	6.88	175	8.13	207	8.13	207
	F	15.55	395	15.45	391	15.55	395	15.45	391	15.45	391	

NOTES:

1. See Coil Connection Table located on Page 11.

**STANDARD FEATURES (Vertical Basic Fan Coils)****Construction***All Units*

- AHRI Standard 440 certified and labeled
- Galvanized steel construction
- Insulation, elastomeric closed cell foam
- Integral filter rack with 1" throwaway filter

**Concealed Units (RBVR)**

- Top supply with duct collar

**Exposed Units (RBVC & RBVS)**

- Top stamped louver supply grille
- Durable powder coat paint
- End pockets with removable panels
- 18 gauge exterior panel construction
- Flat top (RBVC)
- Sloped top (RBVS)

**Coils**

- Cooling - 3 or 4 row chilled water or DX, heat pump compatible
- Heating - 1 or 2 row hot water or steam – reheat position
- 3/8" O.D. seamless copper tubes
- 0.012" tube wall thickness
- High efficiency aluminum fin surface for optimizing heat transfer, pressure drop and carryover
- Left or right hand, same or [opposite - TVB only] end connections
- Removable for service
- Manual air vents

**Drain Pans**

- Single wall, galvanized steel, externally insulated
- Double sloped to drain connection
- 3/4" M.P.T. auxiliary drain pan connection
- Double wall plastic auxiliary drip pan

**Fan Assemblies**

- Forward curved, DWDI centrifugal type
- 115 volt, single phase, three speed PSC motors
- Quick disconnect motor connections
- Removable for service

**Electrical**

- cETL listed for safety compliance
- Electrical junction box for field wiring terminations
- Terminal block for field connections

**Electric Heat**

- Finned tubular element on all floor mounted units protects against electrical shock
- ETL listed as an assembly for safety compliance
- Integral electric heat assembly with removable elements for easy service
- Automatic reset primary and back-up secondary thermal limits
- Single point power connection

**OPTIONAL FEATURES (Vertical Basic Fan Coils)****Construction***All units*

- Manual and motorized outside air dampers
- Spare 1" throwaway filters
- 1" pleated filters (MERV 8 and 13)
- Wall boxes
- Leveling legs

**Concealed Units (RBVR)**

- Wall recessing panels

**Exposed Units (RBVC & RBVS)**

- Linear bar discharge grille, powder coated
- 16 gauge front panel
- Return air louver grille
- 2" - 8" falsebacks
- Extended end pockets
- Tamper proof fasteners

**Coils**

- Automatic air vents
- Stainless steel coil casings
- 1/2" O.D. seamless copper tubes
- 0.016" tube wall thickness
- 0.025" tube wall thickness

**Drain Pans**

- Stainless steel construction with external insulation
- Double wall plastic auxiliary drain pan -- extended length
- Stainless steel auxiliary drain pan -- extended length

**Fan Assemblies**

- 208-230 & 277 volt, single phase, three speed PSC motors
- 115, 208-230 & 277 volt, single phase, three speed EC motors

**Electrical**

- SCR fan speed controller (High speed only)
- Fan relay packages
- Silent solid state fan relays
- Toggle disconnect switch
- Condensate overflow switch (auxiliary drain pan)
- Main fusing
- Unit and remote mounted three speed fan switches

**Electric Heat**

- Door interlocking disconnect switches
- Main fusing
- Silent relay/contactors

**Piping Packages**

- Factory assembled - shipped loose for field installation
- 1/2" and 3/4", 2 and 3-way normally closed, two position electric motorized valves
- Isolation ball valves with memory stop
- 4 pipe with 3-way valve
- Fixed and adjustable flow control devices
- Unions and P/T ports
- Modulating control valves
- High pressure close-off actuators (1/2" = 50 PSIG; 3/4" = 25 PSIG)

**Thermostats**

- Analog, digital display, or programmable
- Unit and remote mounted, with integral three speed fan switch
- 2 and 4-pipe control sequences
- Automatic and manual changeover

**RBVR**

## Revision History

Revision Date	Version Date	Initiated By	Description
09/05/19	07/25/18	J.Letterman	updated drawing page 2, corrected improper dimension callout...should be "D" not "H"